



# MW95A Belt Weigher Instrument

## Technical Information

## ModWeigh

### FEATURES

- Flowrate measurement for belt weighers
- Removable P-Module holds calibration settings
- Flowrate Output
- Material Totaliser
- 4 or 8 Digital inputs
- 4 or 8 Digital outputs
- Modbus communications (independent RS232 and RS485 ports)
- Field software upgrades
- 12-24Vdc power supply
- Overall accuracy better than 0.01%

### HOUSING OPTIONS

- MTxR DIN Rail mounting (IP00)
- MTxF Field housing (IP67)
- MTxG Field housing, Rail mount (IP67)
- MT6x Size 170 x 80 x 70mm
- MT8x Size 230 x 80 x 70mm

### OPTIONS

- MO2 4-20mA or 0-10V input and 4-20mA output
- ±5V excitation for safety barrier applications

### Application

A ModWeigh MW95 Belt Weigher System is used to measure the flowrate of material carried by a belt conveyor.

It measures the belt loading and belt speed and calculates the material flowrate.

### ModWeigh Display

A ModWeigh MW99d4 or MD1 Flowrate Indicator is used to calibrate the system and provide a status display of the operating system. It has a graphics display with easy to use menu selection of settings.

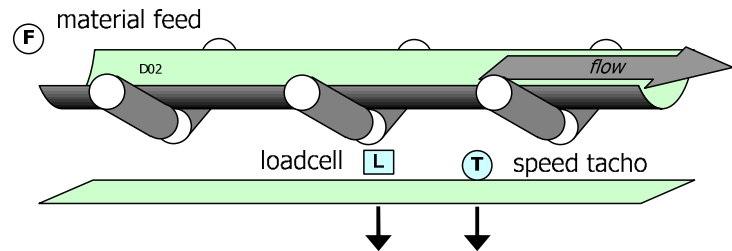

# Features

## Basic

### Units & Resolution

The units for each variable type (weight etc.) can be selected from a list of metric and imperial units. The resolution of each variable type can be adjusted, this alters the count by e.g 100kg displayed in 0.2kg increments.

### OIML Design

The instrument is designed to OIML standards.

### Language Support

Support is available for the following languages: English, Chinese, Korean, German and Spanish.

## Inputs

### Digital Inputs IN1..IN8

The digital inputs are programmable to a range of function including 'acquire zero', 'print' etc.

### Direct & Dynamic Calibration

Direct calibration uses the loadcell capacity and loadcell sensitivity to calibrate the weight signal. Dynamic calibration allows calibration of the weight while the belt is moving knowing the platform weight (kg) or the belt loading (kg/m). This is useful when calibrating is done using chains.

### Corner Adjustment

The excitation voltage can be adjusted on up to four loadcells, allowing differences in loadcell sensitivities to be corrected.

### Tacho Input

The tacho input is used to measure the belt speed and belt travel. Basic calibration is done using a tacho constant setting.

The system can be used to calibrate the tacho by measuring the number of pulses as a known length of belt passes a point. Other belt lengths can be measured in a similar manner.

### Zeroing

The weight of the unloaded belt is averaged over one complete belt revolution and the resulting value is stored as the dynamic zero.

The zeroing can be semi-automated by using an output signal to stop the material feed onto the belt, waiting until the belt is empty, performing the zero averaging, restarting the feed and waiting until material has reached the weigh point before returning to flow control.

Auto zeroing continuously monitors the platform weight. Any small drift in the weight measurement or material build up on the weigh platform is automatically zeroed out. This ensures that with no product on the belt, a zero flowrate is recorded.

### Signal Filtering

Filtering for the weight can be adjusted to get the optimum compromise between reduction of plant vibration and response speed.

## Internal Signals

### Limits

The high and low limits have adjustable setpoints which may be programmed to operate on any internal signal.

### Batching

The system can be used to batch out a desired weight by stopping the feeder when the batch weight has been totalised. A pre-act is available to compensate for overrun.

### Event Collection

Process events are collected for operation with external equipment (PLCs etc.)

### Memory Storage

Allows a group of settings to be stored or recalled from memory. This can be used for example to store settings for different products. There are 20 memory locations with up to 4 settings in each.

### Material Total

The processor incorporates a totaliser which totalises the weight of material through the system. The totaliser can be reset to zero. A pulse output is available to operate external counters. A low flow cutout ensures that low flows do not cause false counts. The total is retained after a power failure.

The totaliser can be set to operate with 5, 6, 7 or 8 digits.

## Outputs

### Material Flowrate

An analog flowrate output signal is available for connection to other instruments.

**Analog I/O Scaling**

The analog output range can be adjusted over the full 0 to 20mA range. The output will drive to a slight negative mA, allowing a live zero to be achieved when using a 0 to 20mA range. A voltage output is easily produced by connecting a resistor to the output.

In addition the analog output signal is selectable to come from any internal signal in the instrument e.g weight, flowrate etc.

**Digital Outputs OUT1..OUT8**

The digital outputs are programmable to operate from any internal signal. These signals include the digital input states, status conditions (running, paused etc) and any fault conditions that are detected. This makes it easy connect into other systems.

**Communications & Display**

**Comms**

RS232 and RS485 ports are available. These are used to connect display to transmitter and also to connect to other systems. The protocol is either ASCII output for example to drive a printer or Modbus for interactive communications. Baud rates and node addresses are programmable.

**Printouts & Macros**

Printouts can be triggered by a key press or set up to occur at set times during the day or week. Data may also be output continuously for data collection purposes. Data is output on the COM1 RS232 port. The content of the printouts is fully programmable using Macros.

Macros are programs used to customise printouts, but can also be used to perform arithmetic calculations. The Macro language also contains conditional terms for more advanced programming.

**Display Customisation**

Locks may be set to prevent unauthorised use of the operator keys and restrict entry to the operator menu. The keys are individually lockable and optionally a passcode can be used to allow authorised operators to use the keys. Alternatively a confirmation of the key action can be requested. The operator MENU can be customised to make additional settings or signals available to the operator.

The contents of the main display can be set to suit any condition, from a comprehensive display showing all operating parameters to a simple display showing the basic signals.

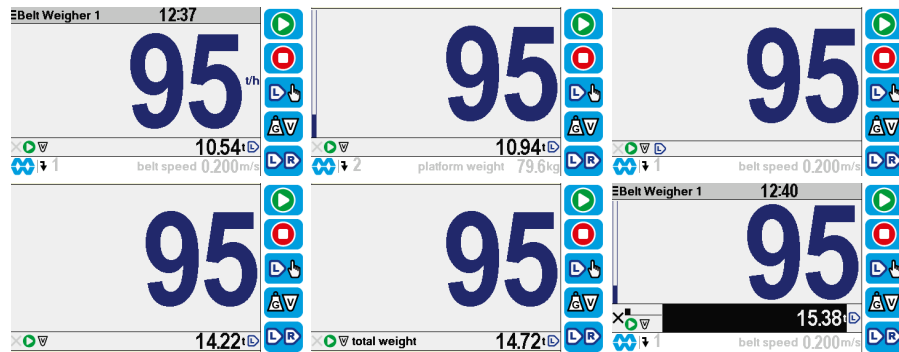

**Computer Connectivity**

An ActiveX control is available to allow programmers to easily communicate with a ModWeigh instrument. Typically this can be used with a Visual Basic programme to collect and write data to the controller.

**ModWeigh I/O**

The function of each input and output is shown in the table below.

The functions of each input or output are user programmable.

		I/O available for each hardware type (& option required)			
		MT2x	MT4x	MT6x	MT8x
Analog inputs	AI1 (loadcell)	●	●	●	●
	AI2 (4-20mA 0-10V)			MO2	MO2
Analog outputs	AO1 (4-20mA)	●	●	●	●
	AO2 (4-20mA)			MO2	MO2
Digital inputs	IN1 pulse input	●	●	●	●
	IN2 acquire zero			●	●
	IN3 run			●	●
	IN4 enable internal tacho			●	●
	IN5 print				●
	IN6 print total				●
	IN7 stop				●
	IN8 pause				●
Digital outputs	OUT1 pulse output	●	●	●	●
	OUT2 running	●	●	●	●
	OUT3 run motor			●	●
	OUT4 healthy			●	●
	OUT5 weight fault				●
	OUT6 belt speed fault				●
	OUT7 material feed				●
	OUT8 alarm alert				●
Communications	COM1 (RS232)	●	●	●	●
	COM2 (RS485)	●	●	●	●

## Specifications

### Loadcell Input AI1

Input Range	±4 mV/V (0-32mV)
Excitation	8 Vdc ±10 %, 250 mA maximum current
Signal processing rate	100 Hz (response time setting ≤ 0.5 s)
Input sensitivity	0.5 µV/division maximum
Zero range	±30 mV.
Zero drift	±0.02 µV+0.0005 % of deadload/°C typical
Span drift	±0.0005 %/°C typical
Non-linearity	<0.002 % of FS
Input noise	0.15 µVp-p typical
Filtering	0.04 s to 32.0 s response time adjustable
Input impedance	>1000 MΩ.
Sense input impedance	>100 kΩ
Sense voltage range	3-10 V

### Analog Input AI2

4-20mA input resistance	47 Ω
0-10V input resistance	>1 MΩ
Isolation	not isolated, all 0V terminals are common

### Analog Outputs AO1 & AO2

Output range	0 to 20 mA (-90 µA to 21 mA, includes standard 4-20mA)
Maximum load	1000Ω @ 24 V supply, 500Ω @ 12 V
Resolution	0.4 µA
Response time	Loadcell response time setting + 20 ms
Voltage output	Use an external resistor to convert mA to volts. For example 500Ω gives 10 V at 20 mA.
Non-linearity	<0.01 %
Drift	<1 µA/°C.

**Digital Inputs IN1..IN8**

High voltage	> 8 V
Low voltage	< 4 V
Maximum voltage	32 V
Input load	3200Ω to 4800Ω
Input type	PNP output sensors

**IN1** frequency input

Maximum range	0.01Hz to 4 kHz
Typical operating range	10 to 1000 Hz
Pulse duty cycle	20% to 80%
Rate of freq change	<20% per ms

**IN1** set to NAMUR

Terminal voltage	8 V
Switching threshold	1.55 mA
Hysteresis	0.2 mA
Namur fault	<0.1 mA or >6 mA

**Digital Outputs OUT1..OUT8**

Max output current	0.25 A
Supply voltage	8 Vdc <+V1 and +V2 <32 Vdc

**OUT1** frequency output

Max frequency	500 Hz
Duty cycle	50 % ±20 % (f > 0.5 Hz)
Max output pulse time	1000 ms (f < 0.5 Hz)

**Communications COM1 & COM2**

COM1 Interface	RS232
COM1 Handshake	CTS can be enabled
COM2 Interface	RS485
Baud rates	9600, 19,200, 38,400, 57,600 and 115,200
Settings	8 data bits, no parity, 2 stop bits (8-N-2)
Protocol	Modbus RTU

**General**

Housing	Polycarbonate UV resistant.
Operating temperature	-10 to 45 °C
Supply voltage	10 to 32 Vdc
Power (transmitter)	2.5 VA @ 100 mA loadcell excitation current 4 VA @ 250 mA loadcell excitation current
Power (display) MW99 or MD1	2 VA

## Dimensions

There is a range of transmitter container sizes available. Each is available either for field mounting or rail mounting.

The display is designed for panel mounting.

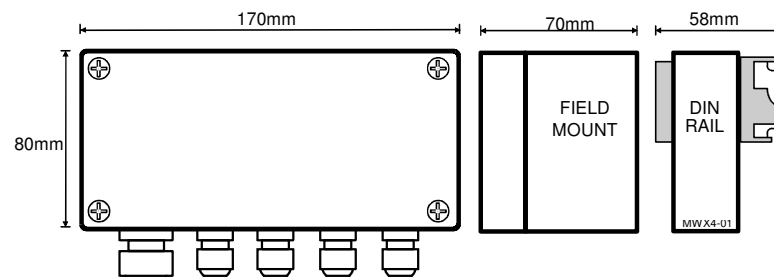
**MT6x Transmitter**

**MT8x Transmitter**

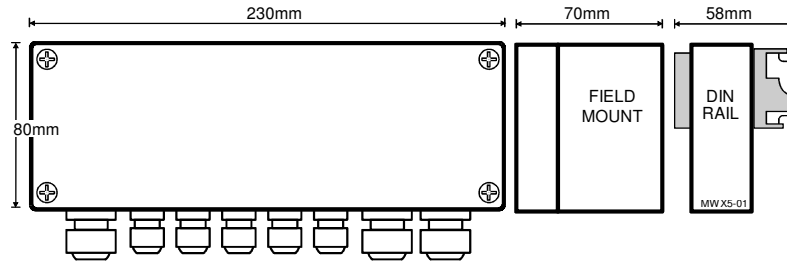

**MW99 Display**

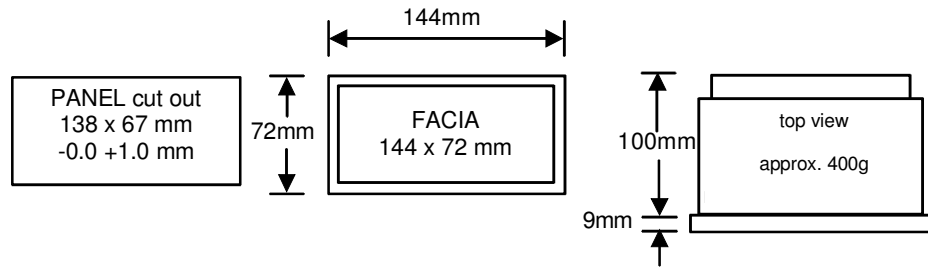

**MD1 Display**

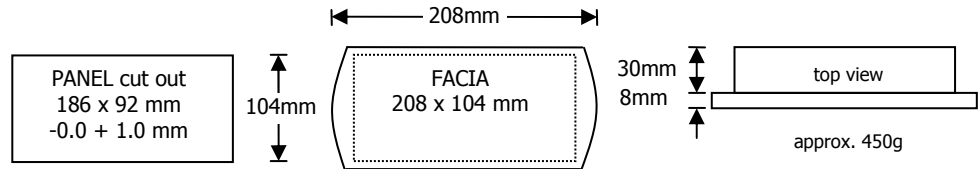

# Connections

## Connection Principles

ModWeigh instruments can be configured in many different ways to suit any given application. The display is normally located to suit an operator. The transmitter can be located in the field to reduce field wiring or can be located with the display for a more conventional approach.

With only one transmitter and one display, the units are typically connected using COM2 (the RS485 port) of each instrument.

### General Connection Principles

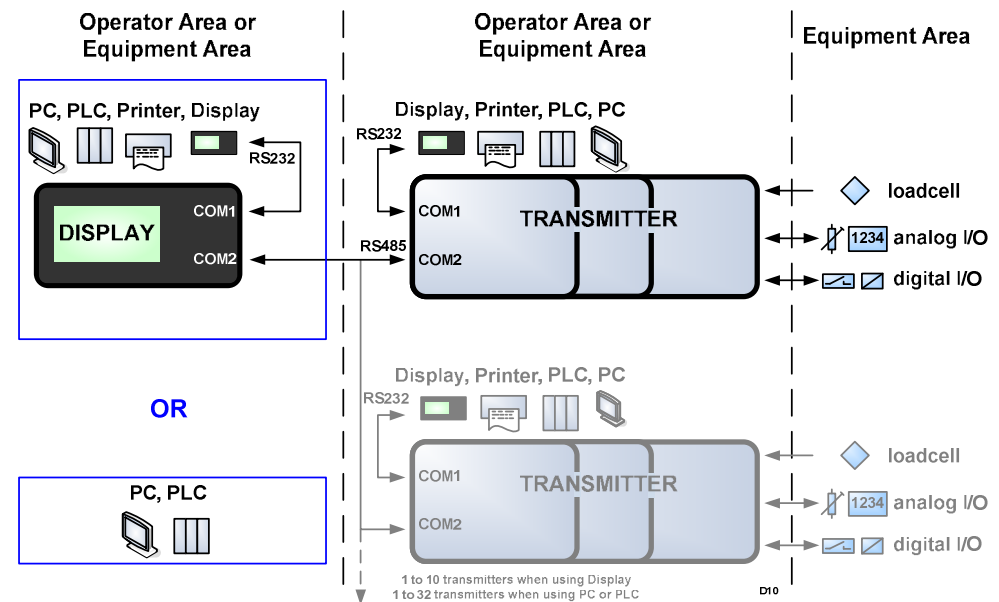

**Transmitter in Control Panel**

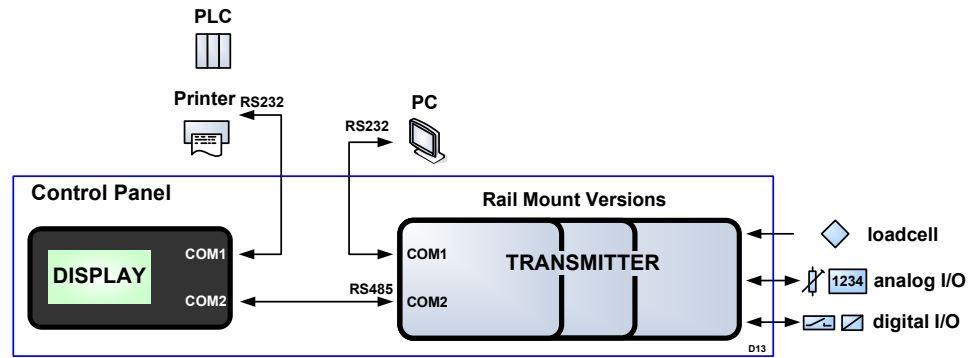

**Transmitter with Equipment**

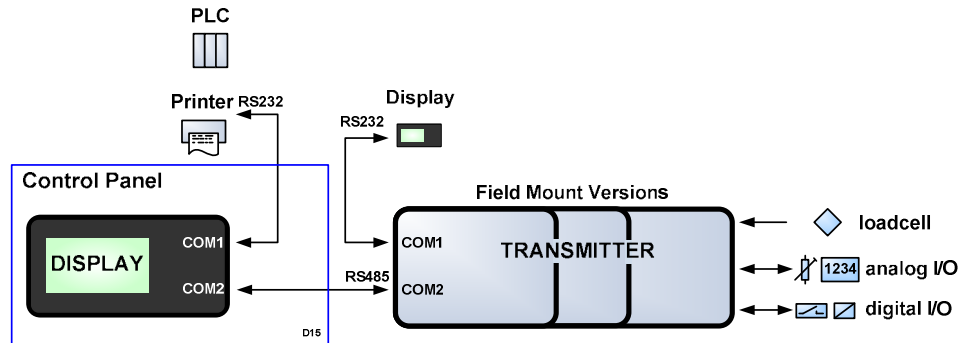

Connection Diagram

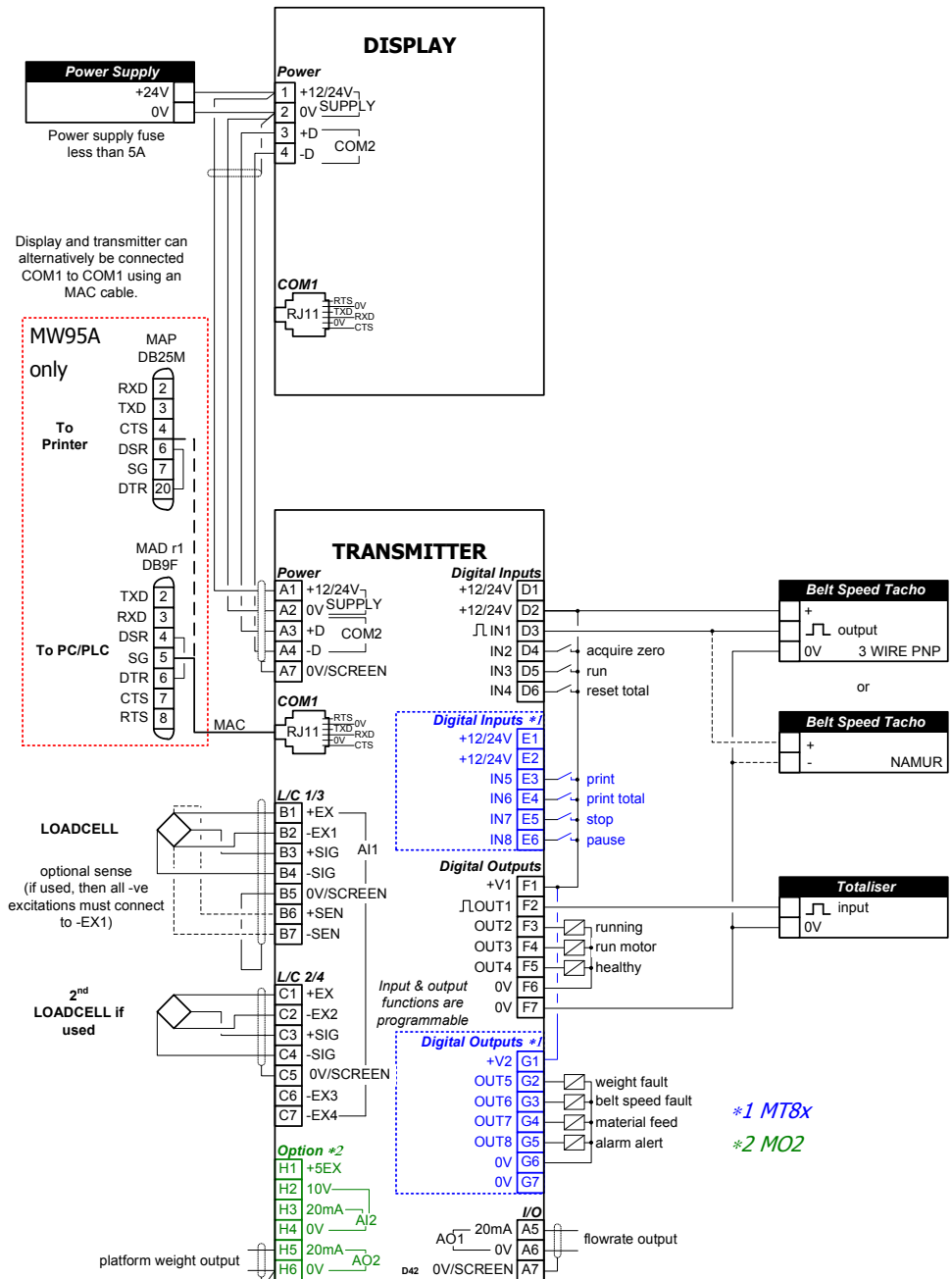



- Keep all wiring separated from mains wiring
- Use shielded cable where indicated
- All 0V terminals internally connected

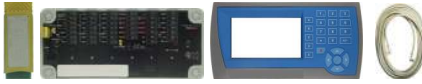

# System Ordering

A ModWeigh system is a group of ModWeigh parts that together form the system. Many possible systems can be created, but most applications will use one of the systems listed below. When ordering, just specify the system order code. To create a custom system, specify the individual components required.

System Order Code	
<b>Belt Weigher Instrument</b>	
2 loadcell terminals <sup>1</sup> , 4 digital inputs/4 digital outputs & display	
	
MW95A, MT6x, MD1, MAC	
rail mount	<b>MW95A,MT6R,MD1,MAC</b>
field housing	<b>MW95A,MT6F,MD1,MAC</b>
field housing, rail mount	<b>MW95A,MT6G,MD1,MAC</b>
<b>Belt Weigher Instrument</b>	
2 loadcell terminals <sup>2</sup> , 8 digital inputs/8 digital outputs & display	
	
MW95A, MT8x, MD1, MAC	
rail mount	<b>MW95A,MT8R,MD1,MAC</b>
field housing	<b>MW95A,MT8F,MD1,MAC</b>
field housing, rail mount	<b>MW95A,MT8G,MD1,MAC</b>

# Parts Ordering

Following is a list of order codes for the individual parts of a ModWeigh system.

The transmitter order code (and options) are shown below. The display is ordered separately, and any accessories (cables etc).

A display is necessary to calibrate and commission a Belt Weigher system. A typical order code list is **MW95A,MT6F,MD1,MAC,MAD** Provides a P-Module, transmitter, a display, a cable and adaptor to connect to a PC

P-Module	Product Module	P-Module order code
	Belt Weigher Instrument	<b>MW95A</b>

Special Options	Special Options	special options order code list
	Chinese manuals	<b>,CH</b>
	Korean manuals	<b>,KO</b>
	No manuals	<b>,NM</b>
	Manufacturing certificate	<b>,MC</b>

<sup>1</sup> Includes 4 loadcell excitations for corner adjustment

<sup>2</sup> Includes 4 loadcell excitations for corner adjustment

**Transmitter**



Transmitter I/O		transmitter order code	
2 loadcell terminals, 4 digital input / 4 digital outputs		<b>6</b>	
2 loadcell terminals, 8 digital input / 8 digital outputs		<b>8</b>	

Transmitter Housing		
Rail mount		<b>R</b>
Field housing		<b>F</b>
Field housing Rail mount		<b>G</b>

,MT

Transmitter options		transmitter option code list	
Analog input/output AI2/AO2 (MT6x & MT8x only) <sup>3</sup>		<b>,MO2</b>	
±5Vdc loadcell excitation (for safety barrier applications) <sup>4</sup>		<b>,MOE1</b>	

**Display**



Display		display order code	
ModWeigh Display		<b>,MD1</b>	
Flowrate Indicator		<b>,MW99d4</b>	

**Accessories**



Accessories		accessory list	
RJ12 Cable 2m (COM1 cable)		<b>,MAC</b>	
RJ12 to 9 pin D-connector adaptor (ModWeigh to PC)		<b>,MAD</b>	
RJ12 to 25 pin D-connector adaptor (ModWeigh to printer)		<b>,MAP</b>	

**Components & Spares**



Components & Spares	
<b>Transmitters</b>	
MT2F/MT2G field mount lid	MCL2x
MT4F/MT4G & MT6F/MT6G field mount lid	MCL4x
MT8F/MT8G field mount lid	MCL8x

Displays	
Display without label	MW99dx
Flowrate Indicator display label	LBL230-6
Pair of display mounting clips	BRK61P
Screw connector for MW99 power connector	TS17-9

**Other ModWeigh Products**

**MW61 Weigher Systems** – loadcells transmitter/indicators. Suitable for scales, vessel weighing and most general weighing applications.

**MW93 Weight Change Systems** – for loss-in-weight and gain-in-weight flow control systems.

**MW94 Impact Weigher Systems** – impact weigher processor for continuous flowrate measurement.

**MW96 Weighfeeder Systems** – weighfeeder processor for continuous flowrate control application of a weighing conveyor.

**Contact Details**



NEW ZEALAND  
 EMC INDUSTRIAL GROUP LTD  
 56 Tarndale Grove, Albany, North Shore, Auckland 0632  
 PO Box 101 444, North Shore, Auckland 0745, New Zealand  
 Phone +64-9-415 5110, Fax +64-9-415 5115  
 Email sales@emc.co.nz      Web www.emc.co.nz

<sup>3</sup> May be fitted in field or ordered with transmitter.

<sup>4</sup> Must be ordered with transmitter (it can not be fitted in the field).



AUSTRALIA  
ACTIVE WEIGHING SOLUTIONS  
Unit 2 / 41-49 Norcal Road, Nunawading, VIC 3131, AUSTRALIA  
PO Box 338, Box Hill, VIC 3128, AUSTRALIA  
Phone +61-3 9873 7677, Fax +61-3 9873 7655  
Email [sales@activeweighing.com.au](mailto:sales@activeweighing.com.au) Web [www.activeweighing.com.au](http://www.activeweighing.com.au)

As we are continuously improving our products, changes to this specification may occur without notice.

(Document Details: g0 g1 g2 g3 g4 g5 g6 g7 g8 g9 g10 g11 g12 g13 g14 g15 MT68x)