



# MW93A Weight Change Instrument Technical Information

## ModWeigh

### FEATURES

- Flowrate measurement and control for loss-in-weight (or gain-in-weight) systems
- Removable P-Module holds calibration settings
- Motor Speed Control Output Signal
- Flowrate Output
- Material Totaliser
- 4 or 8 Digital inputs
- 4 or 8 Digital outputs
- Modbus communications (independent RS232 and RS485 ports)
- Field software upgrades
- 12-24Vdc power supply
- Overall accuracy better than 0.01%

### HOUSING OPTIONS

- MTxR DIN Rail mounting (IP00)
- MTxF Field housing (IP67)
- MTxG Field housing, Rail mount (IP67)
- MT6x Size 170 x 80 x 70mm
- MT8x Size 230 x 80 x 70mm

### OPTIONS

- ±5V excitation for safety barrier applications

### Application

A ModWeigh MW93 Weight Change System is used to control the flowrate of material passing through a weigh hopper and flow regulator. Common flow regulators used for these systems are augers or rotary valves.

The processor is suitable for systems where the flow regulator removes material from a weigh hopper (weight loss system) and systems where the flow regulator adds material to the weigh hopper (weight gain system).

### ModWeigh Display

A ModWeigh MW99d4 or MD1 Flowrate Indicator is used to calibrate the system and provide a status display of the operating system. It has a graphics display with easy to use menu selection of settings.

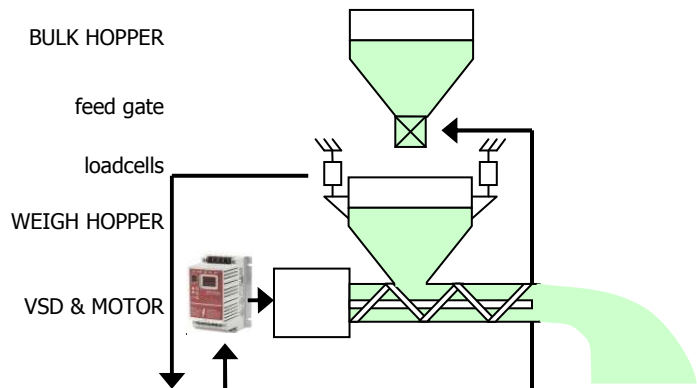

# Features

## Basic

### Units & Resolution

The units for each variable type (weight etc.) can be selected from a list of metric and imperial units. The resolution of each variable type can be adjusted, this alters the count by e.g 100kg displayed in 0.2kg increments.

### OIML Design

The instrument is designed to OIML standards.

### Language Support

Support is available for the following languages: English, Chinese, Korean, German and Spanish.

## Inputs

### Digital Inputs IN1..IN8

The digital inputs are programmable to a range of function including 'acquire zero', 'print' etc.

### Direct Calibration

Direct calibration uses the loadcell capacity and loadcell sensitivity to calibrate the weight signal. Large capacity weighing systems can be quickly and accurately calibrated without the need for large test weights.

### Corner Adjustment

The excitation voltage can be adjusted on up to four loadcells, allowing differences in loadcell sensitivities to be corrected.

### Flowrate Setpoint

The setpoint is the flowrate of material the operator wants the flow regulator to convey. The MW93 can control to the local setpoint, which is set using the keypad, or it can control to the optional remote analog setpoint signal. The option MO2 is required for a remote analog setpoint.

### Signal Filtering

Filtering for the weight can be adjusted to get the optimum compromise between reduction of plant vibration and response speed.

## Internal Signals

### Limits

The high and low limits have adjustable setpoints which may be programmed to operate on any internal signal.

### Batching

The system can be used to batch out a desired weight by stopping the feeder when the batch weight has been totalised. A pre-act is available to compensate for overrun.

### Event Collection

Process events are collected for operation with external equipment (PLCs etc.)

### Loop Control

The processor compares the flowrate with the setpoint. A proportional/integral (PI) control technique with feed forward alters the motor speed demand signal to maintain the flowrate at setpoint. Feed forward allows the system to reach the desired set flowrate very quickly and also to respond to changes in setpoint rapidly.

### Volumetric Mode

Normally the controller operates gravimetrically and automatically adjusts the speed demand signal to reach the required flowrate setpoint.

In volumetric mode, the PI control is disabled, and the speed demand is estimated using the feed forward settings.

This allows the system to be kept operating even in the event of a loadcell failure.

### Advanced Control Settings

Feed forward settings can be adjusted and corrections for plant delays (transport delay) can be made. A ratio setting is available to multiply the setpoint signal by a percentage for ratio control applications.

### Hopper Refilling

The processor uses weight setpoints and delays to produce a material feed control signal. In a weight loss system, the feed is opened to refill the weigh hopper from bulk storage when it nears empty. In a weight gain system, the feed is opened to empty the weigh hopper when it nears full. During the filling process, the processor is put into hold during which the flowrate reading and the motor speed demand signal are held constant. This keeps the flow regulator speed constant during refilling when the flowrate can not be measured.

### Automatic Hold

The hopper weight is continuously monitored to automatically detect that filling is occurring or that the hopper has been accidentally knocked. If this is detected, the flowrate signal and speed demand signal

are held constant until the weight returns to normal. This feature ensures that a constant output flowrate is always maintained during a disturbance to the hopper.

### Auto Setup

To make setting up easier, the auto setup facility allows many settings for the processor to be calculated and set automatically.

### Memory Storage

Allows a group of settings to be stored or recalled from memory. This can be used for example to store settings for different products. There are 20 memory locations with up to 4 settings in each.

### Material Total

The processor incorporates a totaliser which totalises the weight of material through the system. The totaliser can be reset to zero. A pulse output is available to operate external counters. A low flow cutout ensures that low flows do not cause false counts. The total is retained after a power failure.

The totaliser can be set to operate with 5, 6, 7 or 8 digits.

## Outputs

### Speed Demand

An analog speed demand output signal is used to drive an externally connected motor controller to vary the flow regulator speed.

### Material Flowrate

An analog flowrate output signal is available for connection to other instruments.

### Analog I/O Scaling

The analog output range can be adjusted over the full 0 to 20mA range. The output will drive to a slight negative mA, allowing a live zero to be achieved when using a 0 to 20mA range. A voltage output is easily produced by connecting a resistor to the output.

In addition the analog output signal is selectable to come from any internal signal in the instrument e.g weight, flowrate etc.

### Digital Outputs OUT1..OUT8

The digital outputs are programmable to operate from any internal signal. These signals include the digital input states, status conditions (running, paused etc) and any fault conditions that are detected. This makes it easy connect into other systems.

## Communications & Display

### Comms

RS232 and RS485 ports are available. These are used to connect display to transmitter and also to connect to other systems. The protocol is either ASCII output for example to drive a printer or Modbus for interactive communications. Baud rates and node addresses are programmable.

### Printouts & Macros

Printouts can be triggered by a key press or set up to occur at set times during the day or week. Data may also be output continuously for data collection purposes. Data is output on the COM1 RS232 port. The content of the printouts is fully programmable using Macros.

Macros are programs used to customise printouts, but can also be used to perform arithmetic calculations. The Macro language also contains conditional terms for more advanced programming.

### Display Customisation

Locks may be set to prevent unauthorised use of the operator keys and restrict entry to the operator menu. The keys are individually lockable and optionally a passcode can be used to allow authorised operators to use the keys. Alternatively a confirmation of the key action can be requested. The operator MENU can be customised to make additional settings or signals available to the operator.

The contents of the main display can be set to suit any condition, from a comprehensive display showing all operating parameters to a simple display showing the basic signals.

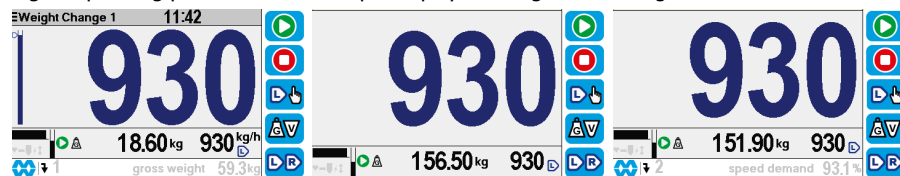

### Computer Connectivity

An ActiveX control is available to allow programmers to easily communicate with a ModWeigh instrument. Typically this can be used with a Visual Basic programme to collect and write data to the controller.

## Configurations

There are three principle configurations for gravimetric flow measurement and control systems. These are Weight Loss, Modified Weight Loss and Weight Gain.

All configurations have the same basic components of a flow regulator and weigh hopper.

**Weight Loss**

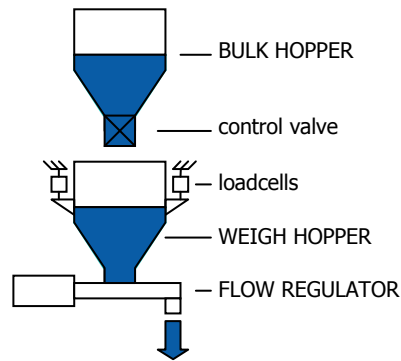

Features

- continuous flow
- weigh hopper & flow regulator combined

**Modified Weight Loss**

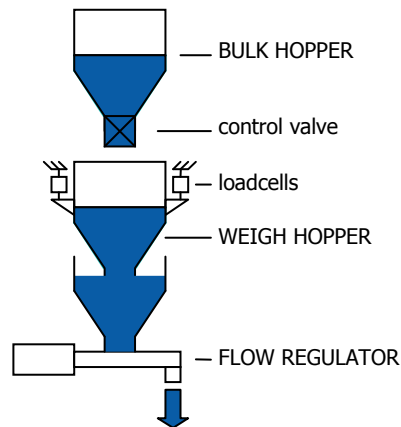

Features

- continuous flow
- weigh hopper isolated from flow regulator combined e.g. plastic extruders



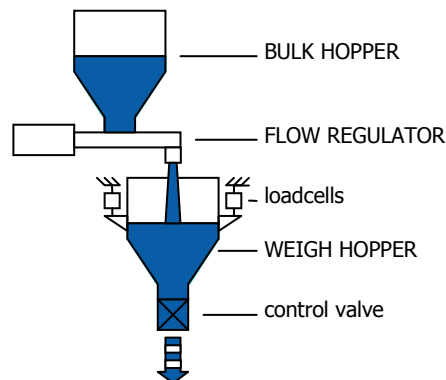

**Weight Gain**



Features

- interrupted flow
- simple installation
- ideal where bulk hopper & feeder already exist

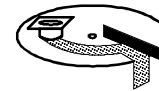
**Flow Regulators**

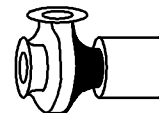
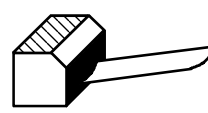
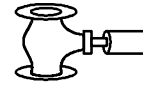
 SCREW FEEDER	 DRUM FEEDER
 BELT FEEDER	 TABLE FEEDER
 ROTARY VALVE	 PUMP
 VIBRATOR FEEDER	 RESTRICTOR VALVE

**Performance**

One factor which determines the performance of a system is the capacity of the loadcell weighing system used to weight the hopper. The following graph gives an indication of the useful operating range that may be used. The Loadcell Capacity is the sum of the capacity of all loadcells, and should take into account any lever system if one exists.

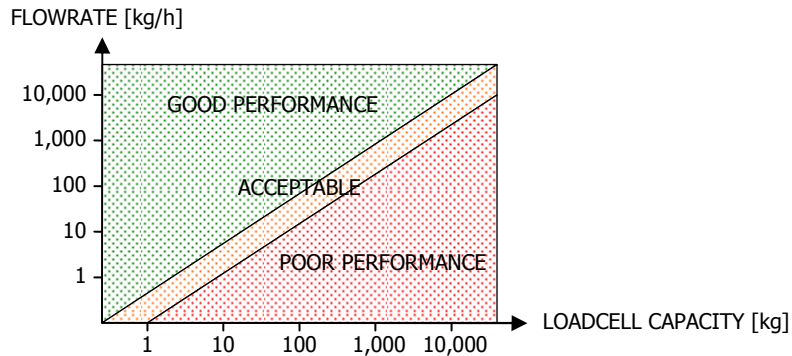

The performance is very dependent on the weighing system repeatability. It is desirable to aim for as high a repeatability as possible. With care, it is possible to achieve weighing repeatability of 1 part in 10,000 to 1 part in 100,000.

Note that other factors may also limit the performance.

Watch flexible couplings to the weigh hopper, as these can easily reduce the achievable performance.

Good accuracy also requires repeatable results from the flow regulator system. Some materials can be difficult to control (for example powders that fluidise)

**ModWeigh I/O**

The function of each input and output is shown in the table below.

The functions of each input or output are user programmable.

		I/O available for each hardware type (& option required)			
		MT2x	MT4x	MT6x	MT8x
Analog inputs	AI1 (loadcell)	●	●	●	●
	AI2 (4-20mA 0-10V)			MO2	MO2
Analog outputs	AO1 (4-20mA)	●	●	●	●
	AO2 (4-20mA)			MO2	MO2
Digital inputs	IN1 hold control	●	●	●	●
	IN2 acquire zero			●	●
	IN3 run			●	●
	IN4 reset total			●	●
	IN5 print				●
	IN6 print total				●
	IN7 run				●
	IN8 pause				●
Digital outputs	OUT1 pulse output	●	●	●	●
	OUT2 material feed	●	●	●	●
	OUT3 run motor			●	●
	OUT4 healthy			●	●
	OUT5 weight fault				●
	OUT6 low flow				●
	OUT7 not filling or discharging				●
	OUT8 alarm alert				●
Communications	COM1 (RS232)	●	●	●	●
	COM2 (RS485)	●	●	●	●

## Specifications

### Loadcell Input AI1

Input Range	±4 mV/V (0-32mV)
Excitation	8 Vdc ±10 %, 250 mA maximum current
Signal processing rate	100 Hz (response time setting ≤ 0.5 s)
Input sensitivity	0.5 µV/division maximum
Zero range	±30 mV.
Zero drift	±0.02 µV+0.0005 % of deadload/°C typical
Span drift	±0.0005 %/°C typical
Non-linearity	<0.002 % of FS
Input noise	0.15 µVp-p typical
Filtering	0.04 s to 32.0 s response time adjustable
Input impedance	>1000 MΩ.
Sense input impedance	>100 kΩ
Sense voltage range	3-10 V

### Analog Input AI2

4-20mA input resistance	47 Ω
0-10V input resistance	>1 MΩ
Isolation	not isolated, all 0V terminals are common

### Analog Outputs AO1 & AO2

Output range	0 to 20 mA (-90 µA to 21 mA, includes standard 4-20mA)
Maximum load	1000Ω @ 24 V supply, 500Ω @ 12 V
Resolution	0.4 µA
Response time	Loadcell response time setting + 20 ms
Voltage output	Use an external resistor to convert mA to volts. For example 500Ω gives 10 V at 20 mA.
Non-linearity	<0.01 %
Drift	<1 µA/°C.

**Digital Inputs IN1..IN8**

High voltage	> 8 V
Low voltage	< 4 V
Maximum voltage	32 V
Input load	3200Ω to 4800Ω
Input type	PNP output sensors

**Digital Outputs OUT1..OUT8**

Max output current	0.25 A
Supply voltage	8 Vdc <+V1 and +V2 <32 Vdc

**Communications COM1 & COM2**

COM1 Interface	RS232
COM1 Handshake	CTS can be enabled
COM2 Interface	RS485
Baud rates	9600, 19,200, 38,400, 57,600 and 115,200
Settings	8 data bits, no parity, 2 stop bits (8-N-2)
Protocol	Modbus RTU

**General**

Housing	Polycarbonate UV resistant.
Operating temperature	-10 to 45 °C
Supply voltage	10 to 32 Vdc
Power (transmitter)	2.5 VA @ 100 mA loadcell excitation current 4 VA @ 250 mA loadcell excitation current
Power (display) MW99 or MD1	2 VA

**Dimensions**

There is a range of transmitter container sizes available. Each is available either for field mounting or rail mounting.

The display is designed for panel mounting.

**MT6x Transmitter**

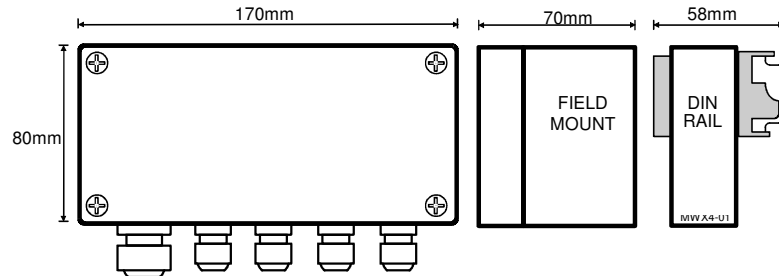

**MT8x Transmitter**

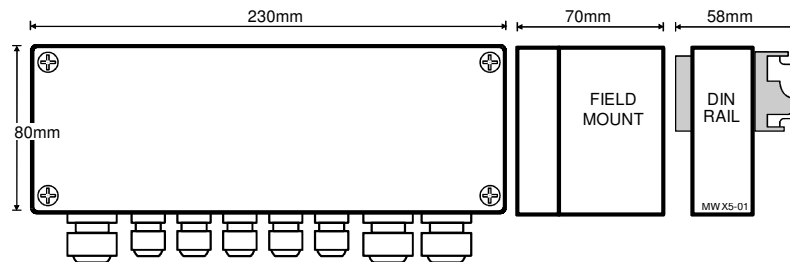

**MW99 Display**

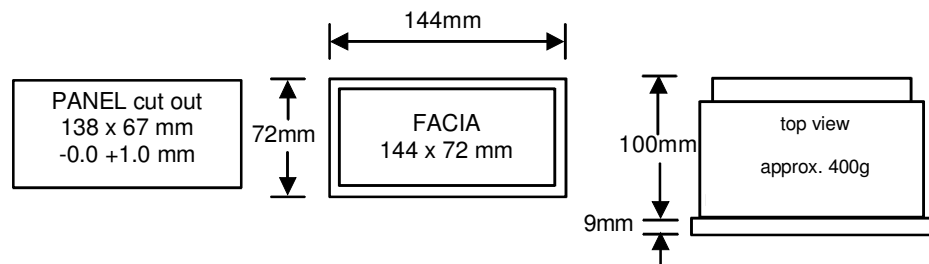

MD1 Display

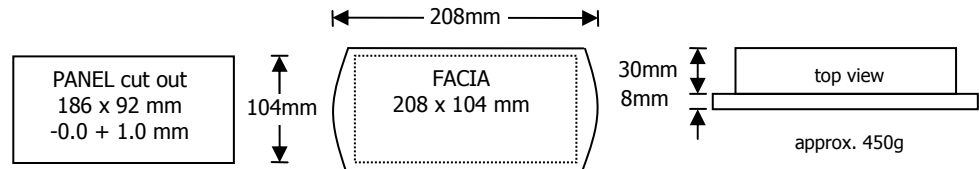

# Connections

## Connection Principles

ModWeigh instruments can be configured in many different ways to suit any given application. The display is normally located to suit an operator. The transmitter can be located in the field to reduce field wiring or can be located with the display for a more conventional approach.

With only one transmitter and one display, the units are typically connected using COM2 (the RS485 port) of each instrument.

### General Connection Principles

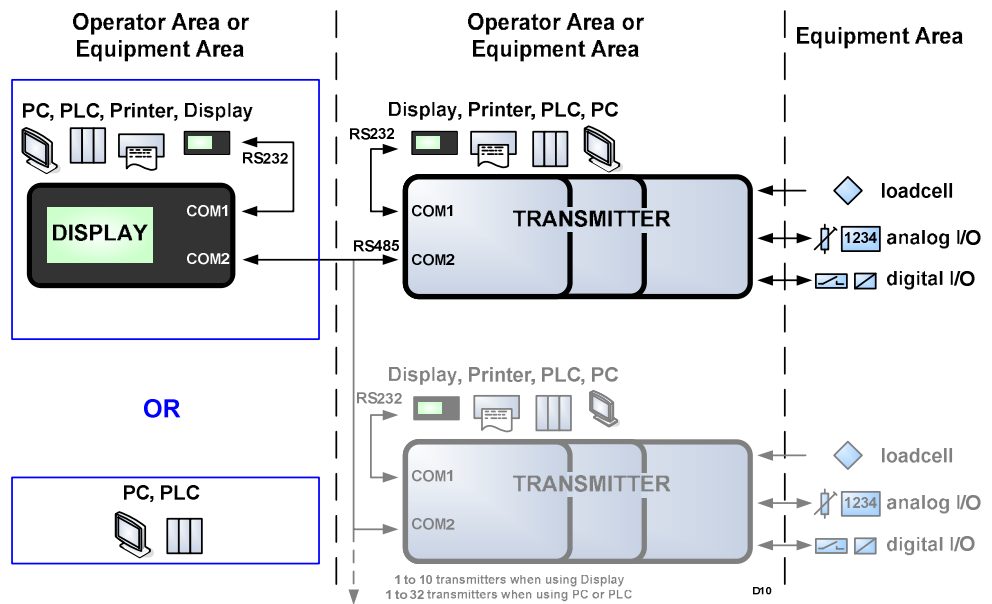

### Transmitter in Control Panel

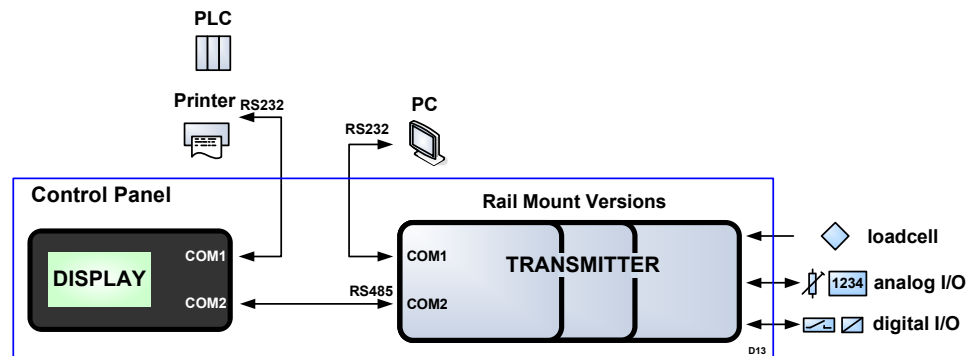



Transmitter with Equipment

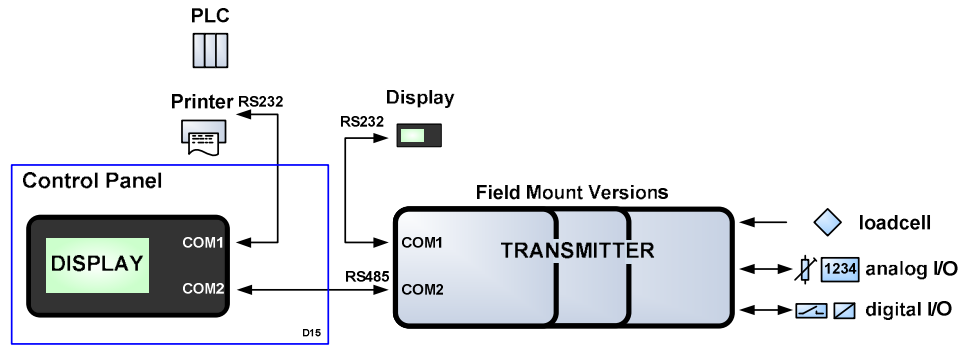

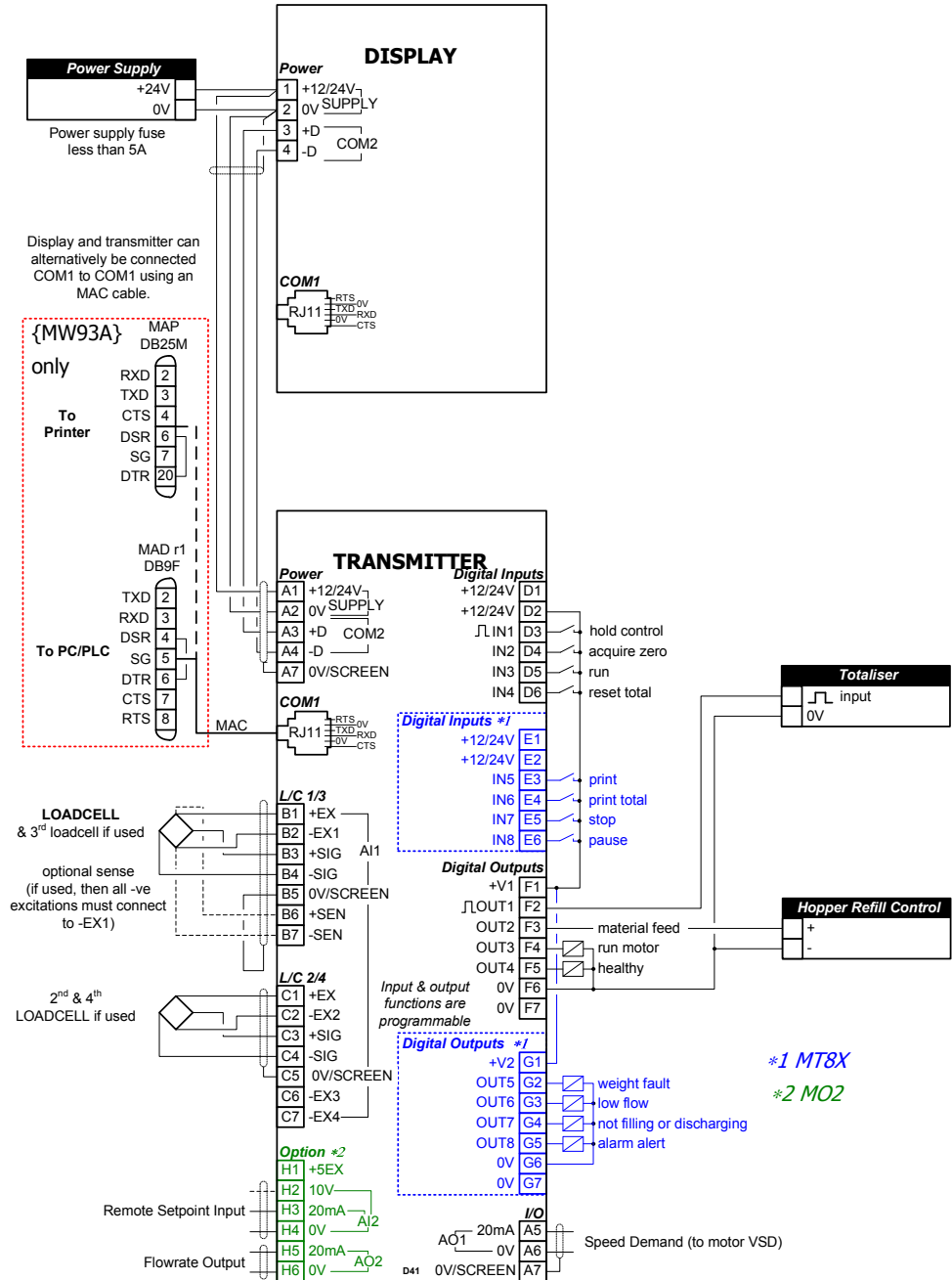

Connection Diagram



- Keep all wiring separated from mains wiring
- Use shielded cable where indicated
- RUN input or RUN MOTOR output should be used
- All 0V terminals internally connected

# System Ordering

A ModWeigh system is a group of ModWeigh parts that together form the system. Many possible systems can be created, but most applications will use one of the systems listed below. When ordering, just specify the system order code. To create a custom system, specify the individual components required.

System Order Code	
<b>Weight Change Instrument</b>	
2 loadcell terminals <sup>1</sup> , 4 digital inputs/4 digital outputs & display	
	
MW93A, MT6x, MO2, MD1, MAC	
rail mount	<b>MW93A,MT6R,MO2,MD1,MAC</b>
field housing	<b>MW93A,MT6F,MO2,MD1,MAC</b>
field housing, rail mount	<b>MW93A,MT6G,MO2,MD1,MAC</b>
<b>Weight Change Instrument</b>	
2 loadcell terminals <sup>2</sup> , 8 digital inputs/8 digital outputs & display	
	
MW93A, MT8x, MO2, MD1, MAC	
rail mount	<b>MW93A,MT8R,MO2,MD1,MAC</b>
field housing	<b>MW93A,MT8F,MO2,MD1,MAC</b>
field housing, rail mount	<b>MW93A,MT8G,MO2,MD1,MAC</b>

# Parts Ordering

Following is a list of order codes for the individual parts of a ModWeigh system.

The transmitter order code (and options) are shown below. The display is ordered separately, and any accessories (cables etc).

A display is necessary to calibrate and commission a Weight Change system. A typical order code list is **MW93A,MT8F,MO2,MD1,MAC,MAD** Provides a P-Module, transmitter, 4-20mA remote setpoint input & 4-20mA flowrate output, a display, a cable and adaptor to connect to a PC.

<b>P-Module</b> 	<b>Product Module</b> <span style="float: right;">P-Module order code</span>
	Weight Change Instrument <span style="float: right;"><b>MW93A</b></span>
<b>Special Options</b>	<b>Special Options</b> <span style="float: right;">special options order code list</span>
	Chinese manuals <span style="float: right;"><b>,CH</b></span>
	Korean manuals <span style="float: right;"><b>,KO</b></span>
	No manuals <span style="float: right;"><b>,NM</b></span>
	Manufacturing certificate <span style="float: right;"><b>,MC</b></span>

<sup>1</sup> Includes 4 loadcell excitations for corner adjustment

<sup>2</sup> Includes 4 loadcell excitations for corner adjustment

**Transmitter**



Transmitter I/O		transmitter order code	
2 loadcell terminals, 4 digital input / 4 digital outputs		6	
2 loadcell terminals, 8 digital input / 8 digital outputs		8	

Transmitter Housing		
Rail mount		R
Field housing		F
Field housing Rail mount		G

,MT

Transmitter options		transmitter option code list	
Analog input/output AI2/AO2 (MT6x & MT8x only) <sup>3</sup>		,MO2	
±5Vdc loadcell excitation (for safety barrier applications) <sup>4</sup>		,MOE1	

**Display**



Display		display order code	
ModWeigh Display		,MD1	
Flowrate Indicator		,MW99d4	

**Accessories**



Accessories		accessory list	
RJ12 Cable 2m (COM1 cable)		,MAC	
RJ12 to 9 pin D-connector adaptor (ModWeigh to PC)		,MAD	
RJ12 to 25 pin D-connector adaptor (ModWeigh to printer)		,MAP	

**Components & Spares**



Components & Spares			
<b>Transmitters</b>			
MT2F/MT2G field mount lid		MCL2x	
MT4F/MT4G & MT6F/MT6G field mount lid		MCL4x	
MT8F/MT8G field mount lid		MCL8x	

Displays			
Display without label		MW99dx	
Flowrate Indicator display label		LBL230-6	
Pair of display mounting clips		BRK61P	
Screw connector for MW99 power connector		TS17-9	

**Other ModWeigh Products**

- MW61 Weigher Systems** – loadcells transmitter/indicators. Suitable for scales, vessel weighing and most general weighing applications.
- MW94 Impact Weigher Systems** – impact weigher processor for continuous flowrate measurement.
- MW95 Belt Weigher Systems** – belt weigher processor for continuous flowrate measurement.
- MW96 Weighfeeder Systems** – weighfeeder processor for continuous flowrate control application of a weighing conveyor.

**Contact Details**



NEW ZEALAND  
 EMC INDUSTRIAL GROUP LTD  
 56 Tarndale Grove, Albany, North Shore, Auckland 0632  
 PO Box 101 444, North Shore, Auckland 0745, New Zealand  
 Phone +64-9-415 5110, Fax +64-9-415 5115  
 Email sales@emc.co.nz      Web www.emc.co.nz

<sup>3</sup> May be fitted in field or ordered with transmitter.  
<sup>4</sup> Must be ordered with transmitter (it can not be fitted in the field).



AUSTRALIA  
ACTIVE WEIGHING SOLUTIONS  
Unit 2 / 41-49 Norcal Road, Nunawading, VIC 3131, AUSTRALIA  
PO Box 338, Box Hill, VIC 3128, AUSTRALIA  
Phone +61-3 9873 7677, Fax +61-3 9873 7655  
Email sales@activeweighing.com.au Web www.activeweighing.com.au

As we are continuously improving our products, changes to this specification may occur without notice.

(Document Details: g0 g1 g2 g3 g4 g5 g6 g7 g8 g9 g10 g11 g12 g13 g14 g15 MT68x)