

PACEPACKER SERVICES

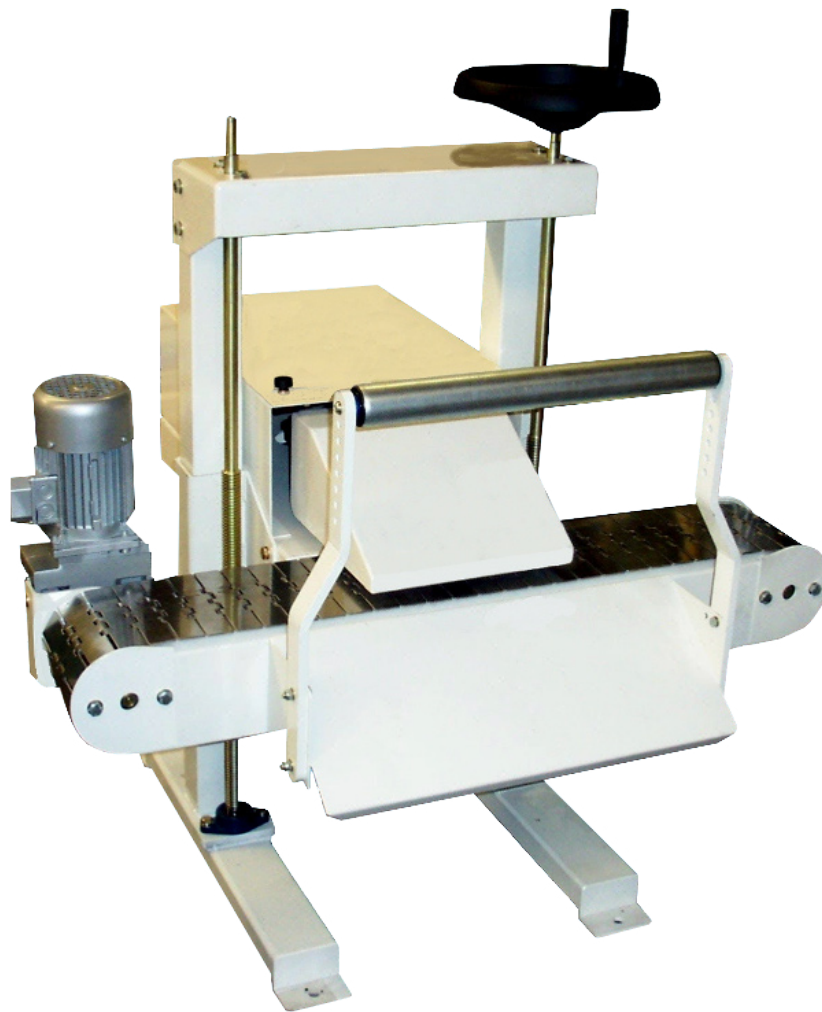

Automation with imagination....



SACK TURNERS

A COMPACT, RELIABLE AND AFFORDABLE RANGE OF BAG
TURNING UNITS THAT ARE FULLY ADJUSTABLE.

PACEPACKER

Operation

Robust construction and clever design enables Pacepacker Sack Turners to give smooth, fast and reliable operation on a wide variety of sack sizes and materials. They are designed to lay down an upright conveyed bag to a flat configuration ready for palletising.

Ninety Degree Turn

The 90 degree Electric Sack Kicker shown on the cover of this brochure is one of the most affordable, accurate and adjustable units available. Available as a stand alone unit or pre-mounted and integrated on a Pacepacker Flat Track Conveyor.

In Line

If your conveyor system is in-line, we manufacture a suitable bag turning option called a Grip Lift and Turn unit. This machine is Pneumatic and Electrically operated and PLC controlled.

Budget In Line

An in line Fall and Turn unit is available as a low cost option suitable for some products and consists of a conveyor with mechanical devices to lay the bag over and position it.

Control System

All turners and kickers are PLC controlled (apart from the budget Fall and Turn unit) and can be added as a stand alone item to your production line or integrated into an existing control system.

Speeds

As many as 30 bags per minute are possible with the Electric Sack Kickers and 15 bags per minute for the Grip Lift and Turn unit.

Electrical Requirements

Standard: 240V, 50/60 Hertz 1 Phase, 2 Amp Supply. Alternatives can be accommodated.

Air Requirements

Cool, clean, dry air at 6 bar (90 PSI) at 27Litres (1 CuFt) per cycle. I.e. 12 cfm at 12 sacks/min 20mm (3/4") supply pipe minimum.

Shipping Specification

Typical Case Size (mm); 1,000x1,000x1,000 high. Average Gross Weight; 150 Kg.



Typical Dimensions Shown, Equipment Manufactured To Suit Each Installation.

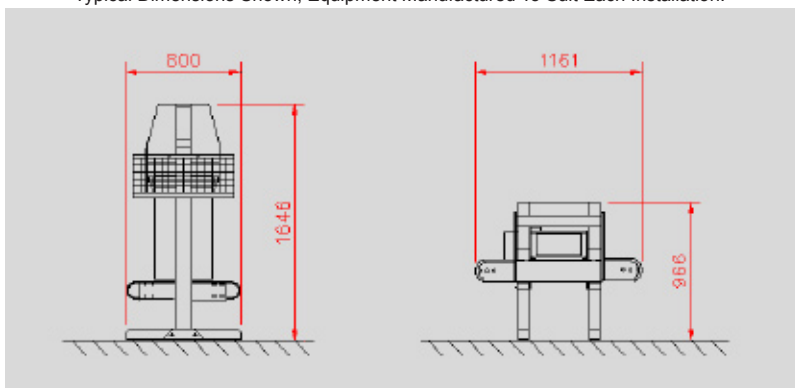

Agent for Australasia



Active Weighing Solutions
Unit 2, 41-49 Norcal Road
Nunawading Vic 3131
Ph: 61 3 9873 7677 Fax: 61 3 9873 7655
Email: sales@activeweighing.com.au
Web: www.activeweighing.com.au