

PACEPACKER SERVICES

Automation with imagination....



SACK FLATTENER

A COMPACT AND RELIABLE UNIT FOR ACCURATE
SACK FLATTENING WITH FULL ADJUSTABILITY.

PACEPACKER

Operation

Robust construction and compact design enables Pacepacker Sack Flatteners to give fast and reliable operation on a wide variety of sack sizes and materials. They are designed to compress a laid down bag to eliminate air and shape evenly ready for palletising.

This is achieved by using compact drum motors and idlers running in opposite directions, feeding the bag into a tapered opening that is easily adjustable for compression height.

The flattener is fitted with a pre-tensioner that allows a certain amount of movement should an oversized bag pass through it or if it is incorrectly set.

Options

Different belt faces are available for different bag and product types.

A variety of overall conveyor lengths are available and in some cases made to order.

Square rolled product settling elevators are also available to settle and level large particle products such as potatoes and other root crops.

Control System

Flatteners are generally supplied as part of a PLC controlled Palletising System, but can be supplied as "motor only" units for connection to a customers control system or isolator switches.

Speeds

Up to 30 bags per minute are obtainable, providing there is a sufficient in-feed speed.

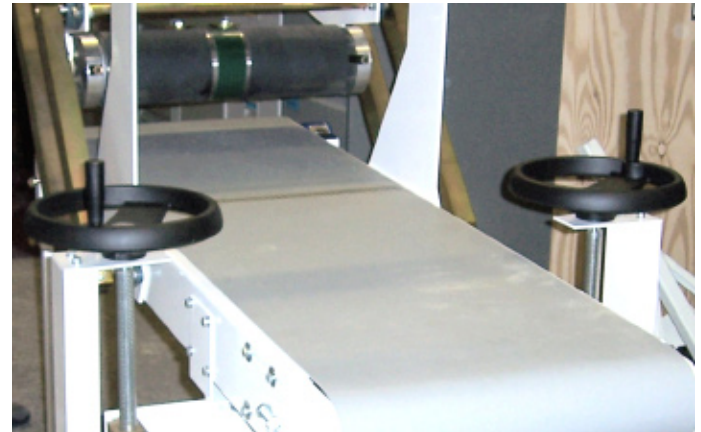
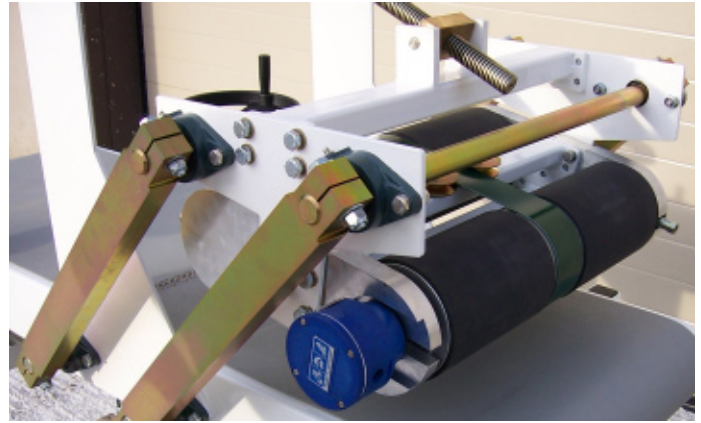

Typical Dimensions Shown, Equipment Manufactured To Suit Each Installation.

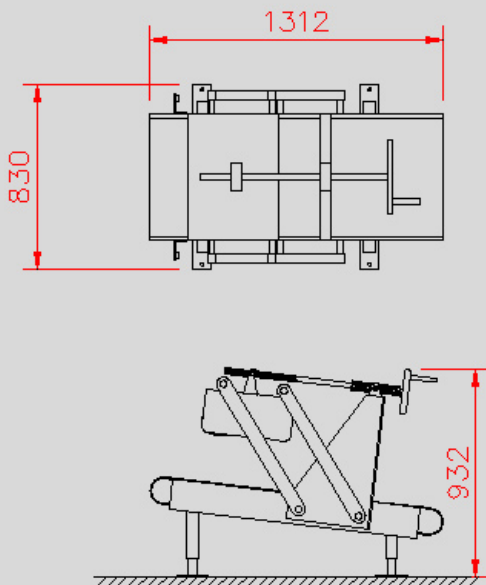

Agent for Australasia



Active Weighing Solutions
Unit 2, 41-49 Norcal Road
Nunawading Vic 3131
Ph: 61 3 9873 7677 Fax: 61 3 9873 7655
Email: sales@activeweighing.com.au
Web: www.activeweighing.com.au